



EV9100-24

Parallel 202 Prefilter

High-volume prefilter system maximizes life of submicron filters



Parallel 202 Prefilter: EV9100-24
EC204 Replacement Cartridge: EV9108-40

BENEFITS

Delivers quality water to high volume fountain dispensers, coffee makers and ice machines where extreme water conditions demand larger capacity filters

Ideal for water supplies with excessive dirt loads

Special dual gradient prefilter cartridges reduce dirt and other particles at least 10 microns in size

Parallel 4" x 20" sumps hold high efficiency cartridges

Extends the life of submicron filter system cartridges

Additional draw down capacity for high volume locations and peak demand times

Includes fittings for connections to existing Everpure filtration systems

INSTALLATION TIPS

Never use saddle valve for connection

Use 3/4" water line

Install vertically with bowls hanging down

Allow 2-1/2" clearance below the cartridge for easy cartridge replacement

Flush cartridges by running water through flushing valve for five minutes at full flow

OPERATION TIPS

Change cartridges on a regular 6 month preventative maintenance program

Change cartridges when capacity is reached or when pressure falls below 10 psi

Service flow rate must not exceed 10.0 gpm

Always flush the filter cartridge at time of installation and cartridge change

APPLICATION/SIZING

Add-on components address high particulate, algae and other related water issues

High volume combination applications

Extends the life of submicron filters

SPECIFICATIONS

Overall Dimensions:

26.06"H x 30"W x 8.5"D

Inlet connection: 3/4"

Outlet connection: 3/4"

Service Flow Rate:

Maximum 10.0 gpm (37.8 Lpm)

Pressure Requirements:

10 - 90 psi (0.7 - 6.2 bar), non-shock

Temperature: 35°F - 100°F (2-38°C)

No electrical connection required

Shipping Weight: Prefilter 32.5 lbs

Operating Weight: Prefilter 41.5 lbs.

The contaminants or other substances removed or reduced by this drinking water system are not necessarily in your water. Do not use with water that is microbiologically unsafe or of unknown quality without adequate disinfection before or after the system. Systems certified for cyst reduction may be used with disinfected water that may contain filterable cysts.

Parallel 202 Prefilter

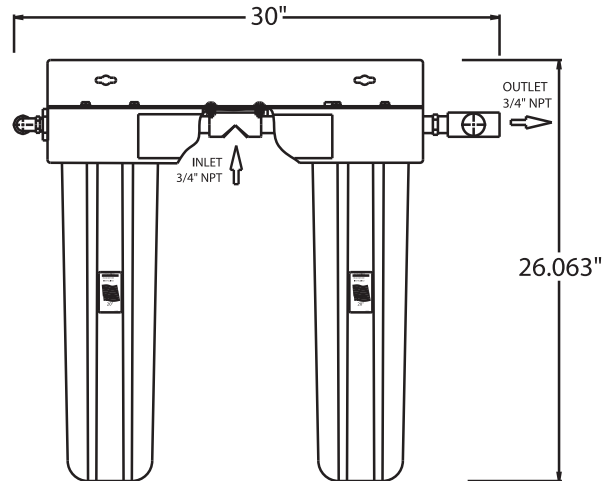

WARRANTY

Everpure water treatment systems (excluding replaceable elements) are covered by a limited warranty against defects in material and workmanship for a period of five years after date of purchase. Everpure replaceable elements (filter cartridges and water treatment cartridges) are covered by a limited warranty against defects in material and workmanship for a period of one year after date of purchase. See printed warranty for details. Everpure will provide a copy of the warranty upon request.

EVERPURE®

EVERPURE, LLC
1040 Muirfield Drive
Hanover Park, Illinois 60133
Toll Free (800) 323-7873
Tel (630) 307-3000
Fax (630) 307-3030
<http://www.everpure.com>

In Europe:
N.V. EVERPURE (EUROPE) S.A.
INDUSTRIEPARK WOLFSTEE
TOEKOMSTLAAN 30
B-2200 HERENTALS
BELGIUM
TEL 32 -14-283500
FAX 32-14-283505

In Japan:
EVERPURE JAPAN LLC
HASHIMOTO MN BLDG. 7F
3-25-1 HASHIMOTO SAGAMIHARA-SHI
KANAGAWA 229-1103
JAPAN
TEL 81-(0)42-775-3011
FAX 81-(0)42-775-3015

Everpure
1040 Muirfield Drive
Hanover Park, IL 60133
Phone: 630-307-3020 Fax: 630-307-3030